

Cette machine inspecte la qualité de la bague avant le remplissage et détecte les ébréchures

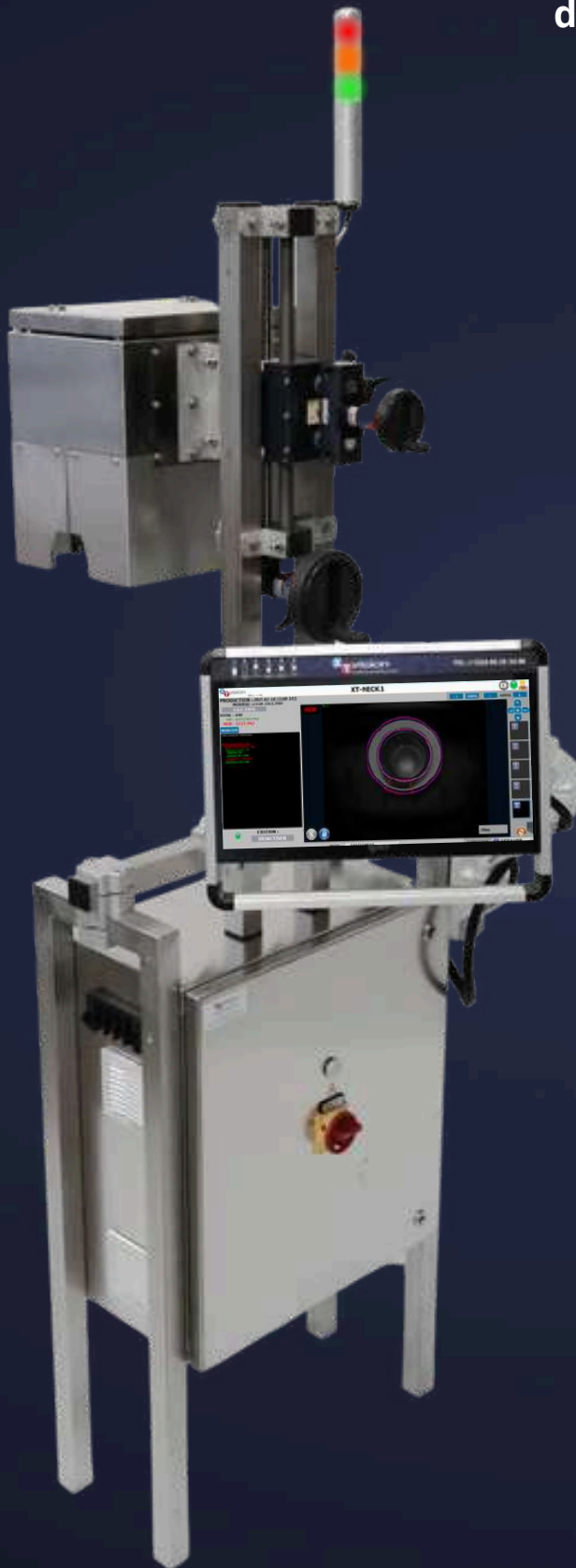

La caméra réalise des images de la bouteille par le dessus



Les images s'affichent sur l'écran afin que l'on puisse avoir un aperçu



Chaque image est analysée par le logiciel de vision

EXEMPLES DE CONTRÔLES



BAGUE PLATE UNIQUE



BAGUE CARRÉE



BAGUE CÉTIE CARRÉE DE 14



BAGUE PLEINE



BAGUE A VIS



BAGUE VINS EFFEVESENTS

DIMENSIONS DE LA MACHINE

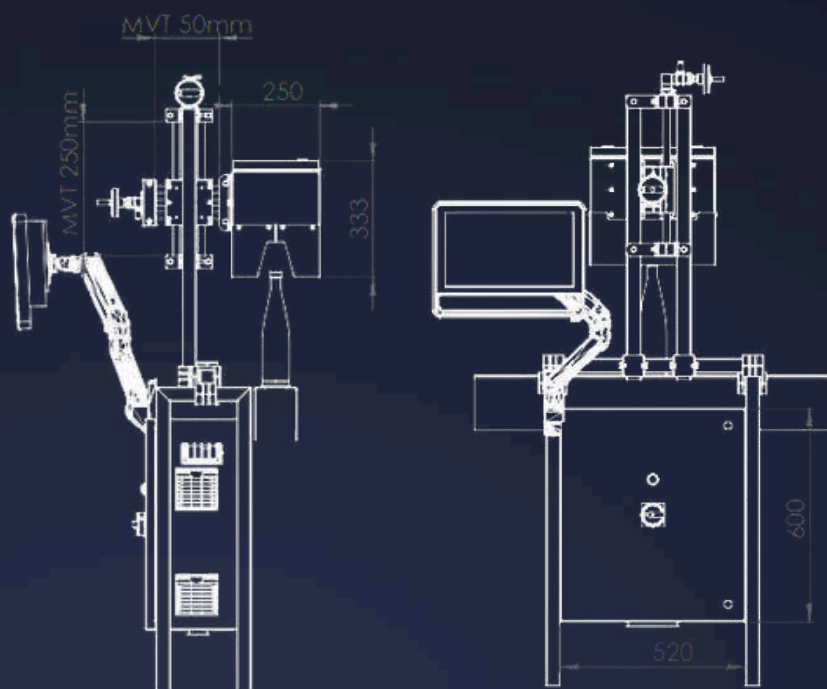

LES POINTS A SAVOIR

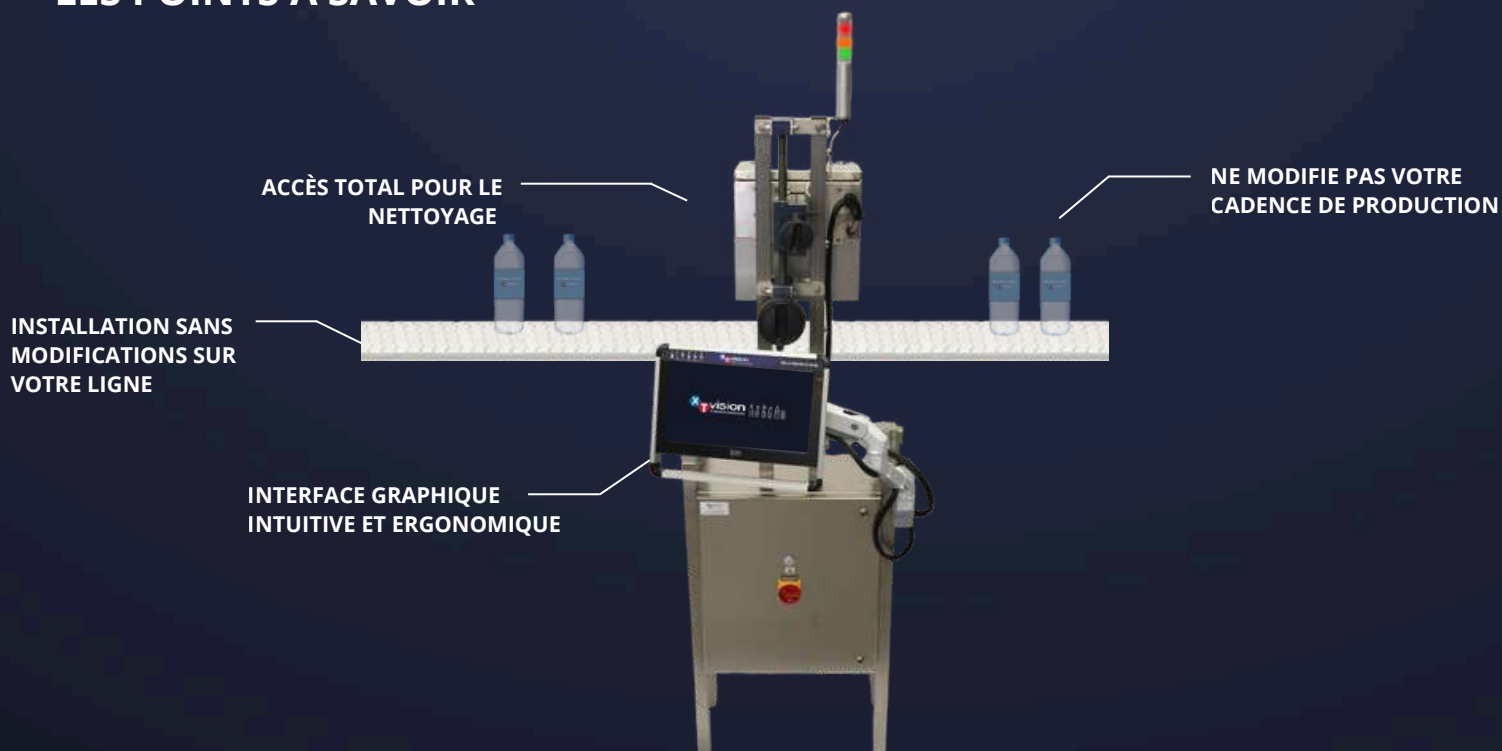

Fabrication Française



contact@xt-vision.com



365 Avenue des Genévriers, 13600 La Ciotat